



FOREST PRODUCTS CAMPAIGN FOR WINTER 2025

Forest products



ITEM NO: 12200
WEIGHT: 2,8 KG

One-size safety kit with 1 pc. cut-resistant trousers class 1 - 9 layers. Adjustable up to XL. Also, 1 pc. Forestry helmet with hearing protection and metal visor. Approval: EN381-5, EN 397, EN352.3, EN 1731, EN 166, CE.

ITEM NO: 12243
WEIGHT: 0,2 KG

One-size-fits-all 8-layer glove with anti-vibration inserts. Approval: Class 1. EN 381-7, EN 420, EN 388.

ITEM NO: 12248
WEIGHT: 0,5 KG

ITEM NO: 12249
WEIGHT: 1 KG

Aluminium wedge.



ITEM NO: 12240
WEIGHT: 0,9 KG

File set for chainsaw chain, incl. vise. The set includes flat/round files for both 4.8 and 4 mm chains. Handles for filing and sharpening, and rider holder. Delivered in canvas bag with lid.



ITEM NO: 12239
WEIGHT: 1,8 KG

Electric grinding machine. For tabletop mounting. Ensures quick sharpening of chains for chainsaws. Grinding stone Ø100 mm included. Can be adjusted in height and desired angle. Delivered partially assembled.

Forest products



ITEM NO: 12237
WEIGHT: 6,2 KG

Metal sawhorse for holding the wood while cutting it into firewood pieces. Stands firmly on the ground with 6 legs, handling up to 180 kg of wood at a time. Can be folded after use. Delivered unassembled.



ITEM NO: 12236
WEIGHT: 5,4 KG
Sawhorse in wood



ITEM NO: 12238
WEIGHT: 11,6 KG

Sawhorse for shortening firewood logs where the chainsaw is attached to the metal stand. The chainsaw can be tilted up and down within the protective shield during cutting. Dimensions: 880x710x960 mm. Delivered unassembled.



Forest products



ITEM NO: 1002774

Log splitter from Scheppach in sturdy powder-coated steel construction. 2-hand operation and hydraulic cylinder with automatic return. Safety grid over the splitting zone.

ITEM NO: 1002777

TECHNICAL DATA:

Engine power: 2200 W absorbert effekt/1700 W avgitt effekt.

Pressure force: 7 T.

Cylinder journey: 37 cm.

Max. trunk length: 52 cm.

Max. diameter of the tree: 25 cm.

Cylinder, propulsion: 3,08 cm/sek.

Cylinder, recoil: 5,29 cm/sek.

ITEM NO: 1002767

Approach the winter confidently with this new firewood saw. With this firewood saw, cutting firewood becomes easy and efficient at a comfortable working height.

TECHNICAL DATA:

Engine power: 2200 watt - 230 V

Revolutions: 2800 rpm

Blade for saw: Ø 405 mm

Cutting capacity: 140 mm

Cutting length min.: 300 mm

Cutting length maks: 1000 mm

Weight netto: 39 kg

Weight brutto: 43 kg



Forest products



ITEM NO: 13119
51cc Gasolin Chainsaw

TECHNICAL DATA:

Engine displacement:51.5cc
Power:2100W
Torque:2.4 N.m
Max speed:11000rpm
Idling speed:2700-3400
Chain&Bar type:Chinese
Guide bar size:18"
Fuel tank capacity:0.5L
Oil tank capacity:0.24L
Oil feeding system:Automatic
Primer:Yes
Start system: Easy start

TECHNICAL DATA:

12V Li-ion- 2.0Ah battery pack
Guide bar length: 158mm=6"
Chain pitch:7.6mm, 14 teeth
No load speed:3700min-1
Cutting width: Dia<100mm
Compact, handy design
SDS chain tension system
With double kick-back production design
Soft grip handle
Fast charge, charging time: 60-90min.
1 x chain saw bare machine
1 x chain, 1 x bar, 1 x chain& bar cover



ITEM NO: 13120
12V Li-ion Mini saw



Forest products



ITEM NO: NEWLOG1
2x20V Brushless chainsaw



TECHNICAL DATA:

Voltage: 40V (2x 20 V)
Brushless motor
No-load speed: 6800rpm
Sword length: 350 mm (14")
Chain speed: 13,0 m/s Cutting length: 350 mm
Saw chain model: 3/8LP
Oil tank capacity: 100 ml
Cutting capacity: 100 x 100mm
Wood: >50pcs (2Ah battery)
Discharge time: 1 hour (2.0AH)

Features:

SDS: Tool Free Chain Tensioning
Automatic Bar and Chain Oiler
Oil level Window
Soft Grip Handle
Electronic Brake

Price including:
2pcs x 2.0Ah battery packs
1pc x fast charger

ITEM NO: NEWLOG2
16.8V Branch shear

TECHNICAL DATA:

Operating Voltage:16.8V
Lithium Battery:16.8V/2AH
Charging Voltage: AC100V-220V
Charging duration:1-1.5hours
Rated Power:100W
Max Power:500w
Cutting Diameter:25mm
Length:350mm
Included 1battery and 1 charger



Forest products



ITEM NO: NEWLOG3

LOGSAW 405 MM WITH GS-CE-ROHS-EMC APPROVAL.

TECHNICAL DATA:

Log saw 405 mm - IP54

Motor: 230V, 50Hz, 2200W

Blade: 405xØ30 mm

Rotation speed: 2800 rpm

Max cutting diameter: 140 mm

Weight: 41 kg

Packing size: 106*700*36,6cm/1pcs

WITH GS-CE-ROHS-EMC AP-

PROVAL.



ITEM NO: NEWLOG4

8 tons vertical log splitter

TECHNICAL DATA:

Log Splitter 8 Ton - IP54

Model: 230V

Max splitting force: 8 ton

Splitting length: 100-550 mm

Max log diameter: 80-300 mm

Electric motor: 230V, 50Hz, 3500W

Weight: 117 kg

WITH GS-CE-ROHS-EMC AP-

PROVAL.

Forest products

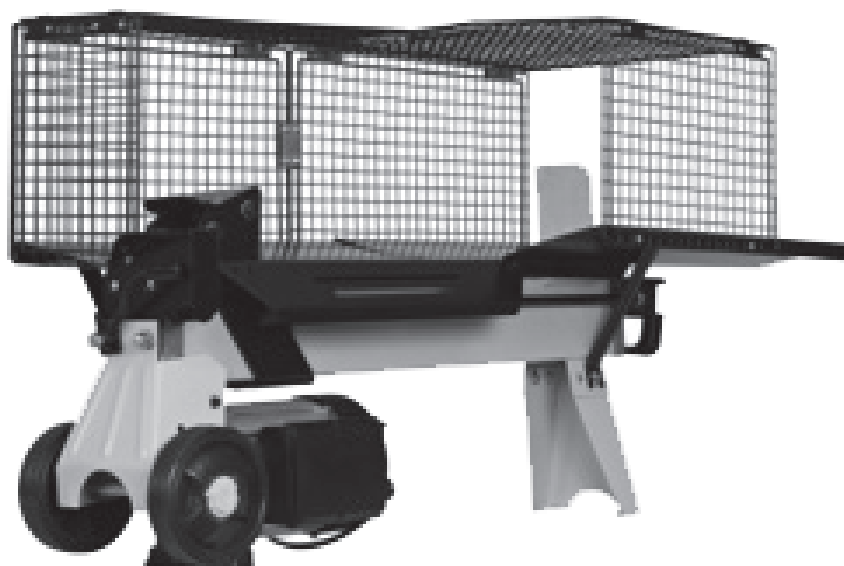

ITEM NO: NEWLOG5 4 TON

Log splitter

TECHNICAL DATA:

Motor: 230V-50Hz - IP54

Power: 1500W

Max. Splitting force: 4 tons

Log capacity: Diameter 50-250 mm

Length: 370 mm

Hydraulic oil capacity: 1.8 L

With steel cage

Packing Size: 950×320×500mm



Stand:

Item no: NEWLOG8

ITEM NO: NEWLOG7 7 TON

Log splitter

TECHNICAL DATA:

Motor: 230V-50Hz

Power: 2300W

Max. Splitting force: 7 tons

Log capacity: Diameter 50-250 mm

Length: 520 mm

Hydraulic oil capacity: 1.8L

with steel cage

Packing Size: 950×320×500mm

ITEM NO: NEWLOG6 6 TON

Log splitter

TECHNICAL DATA:

Motor: 230V-50Hz

Power: 2000W

Max. Splitting force: 6 tons

Log capacity: Diameter 50-250 mm

Length: 520 mm

Hydraulic oil capacity: 1.8L

with steel cage

Packing Size: 950×320×500mm